

762 diameter flat sealed composite cover and frame.

For reference purposes only. This drawing is not a specification. Order against product code only. To enable continuous improvement of our products, the designs and specifications are subject to change without notice.

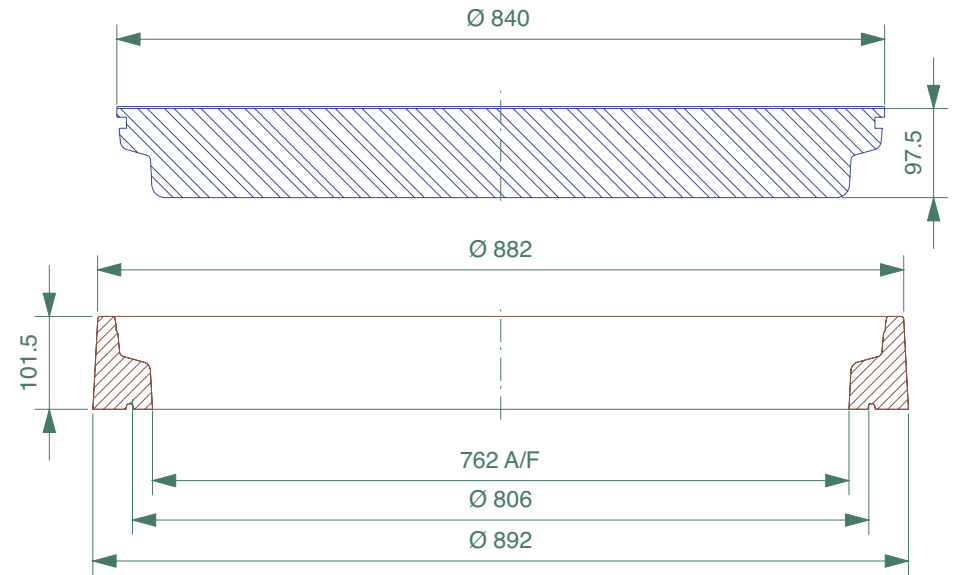
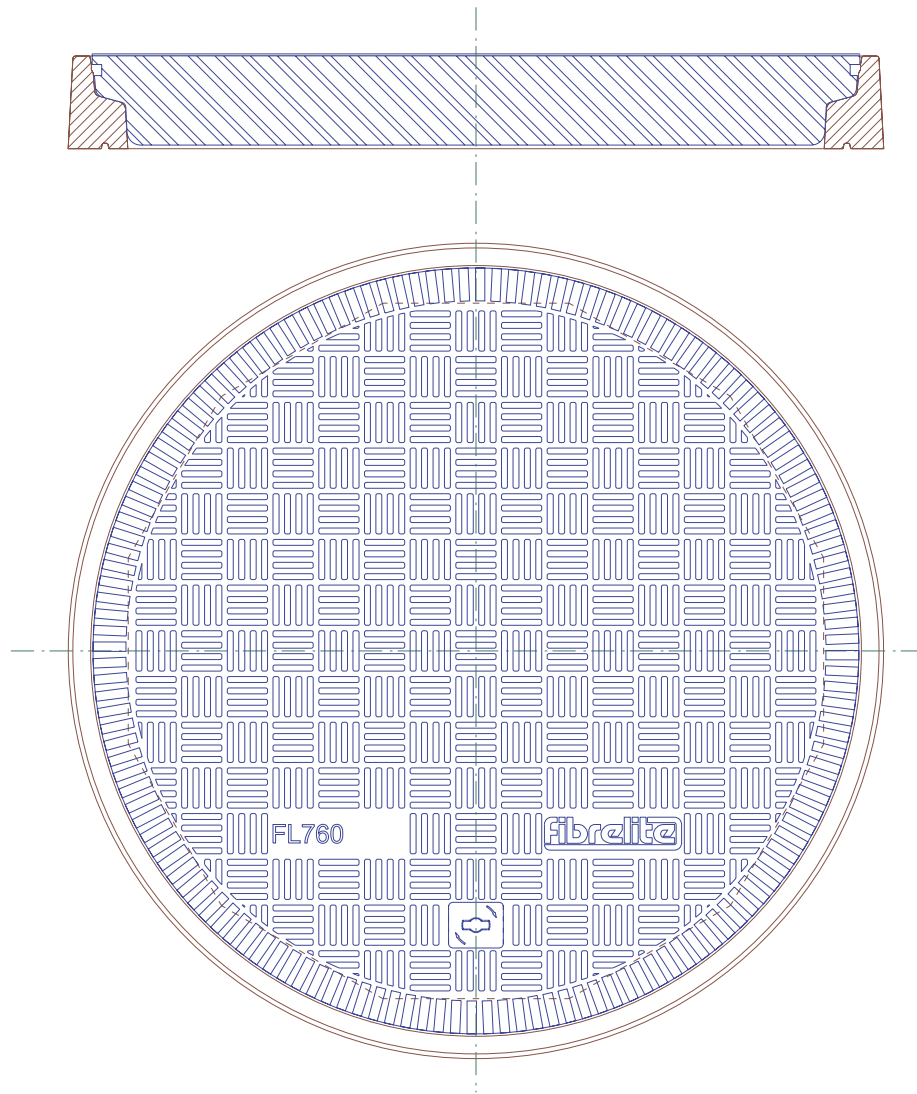

Load Rating	Cover Weight	Frame Weight
B125	--	8 kg
C250	27 kg	8 kg
D400	36 kg	8 kg

762 diameter flat sealed composite cover and frame.

For reference purposes only. This drawing is not a specification. Order against product code only. To enable continuous improvement of our products, the designs and specifications are subject to change without notice.

CONCRETE

VERY IMPORTANT

OUTER EDGE "A" OF FRAME SET 5MM ABOVE GENERAL FORECOURT AREA WITH CONCRETE RAMPED AWAY OVER 300MM

VERY IMPORTANT

The underside of the frame must be adequately supported by concrete.

Expansion joint filled with petrol resistant mastic.

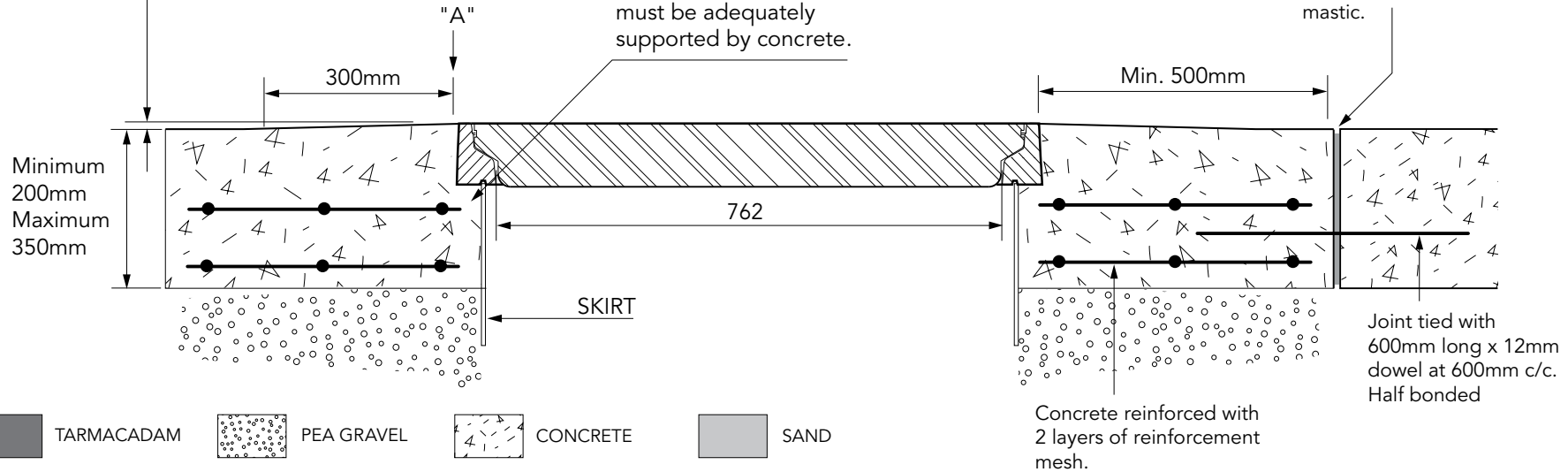

- TARMACADAM
- PEA GRAVEL
- CONCRETE
- SAND

Concrete reinforced with 2 layers of reinforcement mesh.

Joint tied with 600mm long x 12mm dowel at 600mm c/c. Half bonded

TARMACADAM

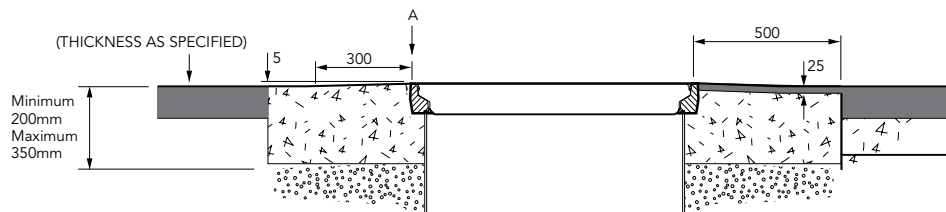

SETTS

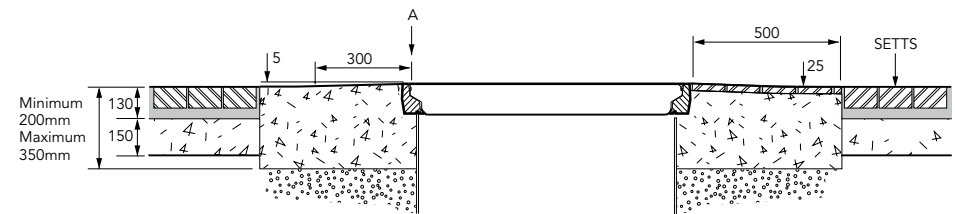

762 diameter flat sealed composite cover and frame.

For reference purposes only. This drawing is not a specification. Order against product code only. To enable continuous improvement of our products, the designs and specifications are subject to change without notice.

