

1.5m diameter 12 sided sump with reverse flange, corbel, adjustable height skirt, internal lid, and round 1020mm flat sealed cover and frame.

S16-3100

© Copyright

Issue: 04/06/2015

Page: 1 of 4



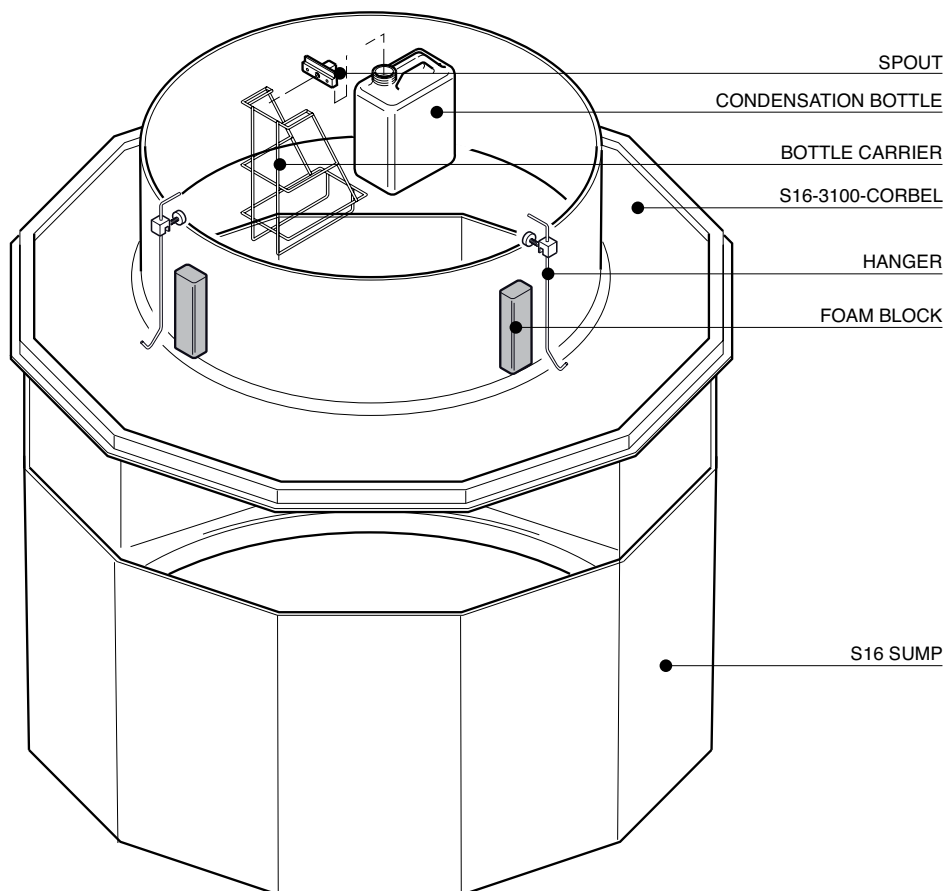
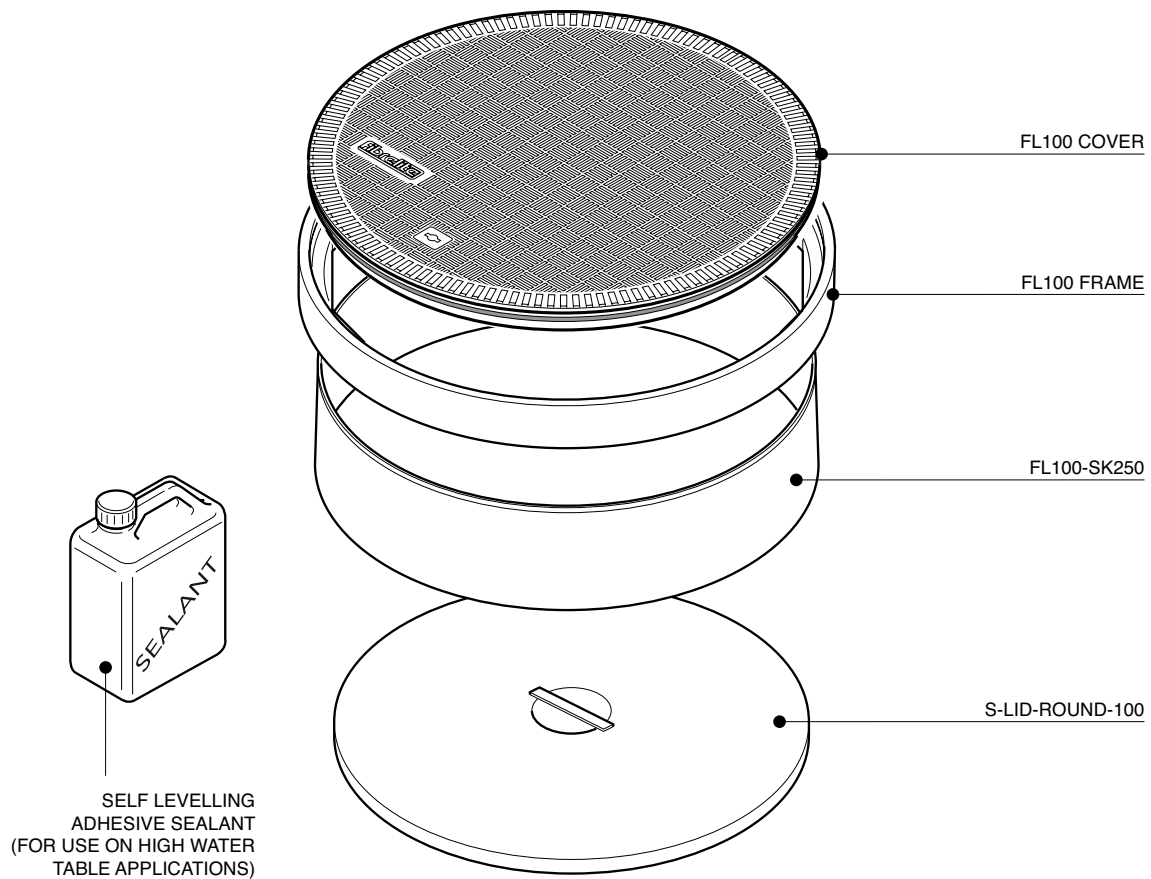

1.5m diameter 12 sided sump with reverse flange, corbel, adjustable height skirt, internal lid, and round 1020mm flat sealed cover and frame.

24 No. Ø13 HOLES
ON 1330 PCD

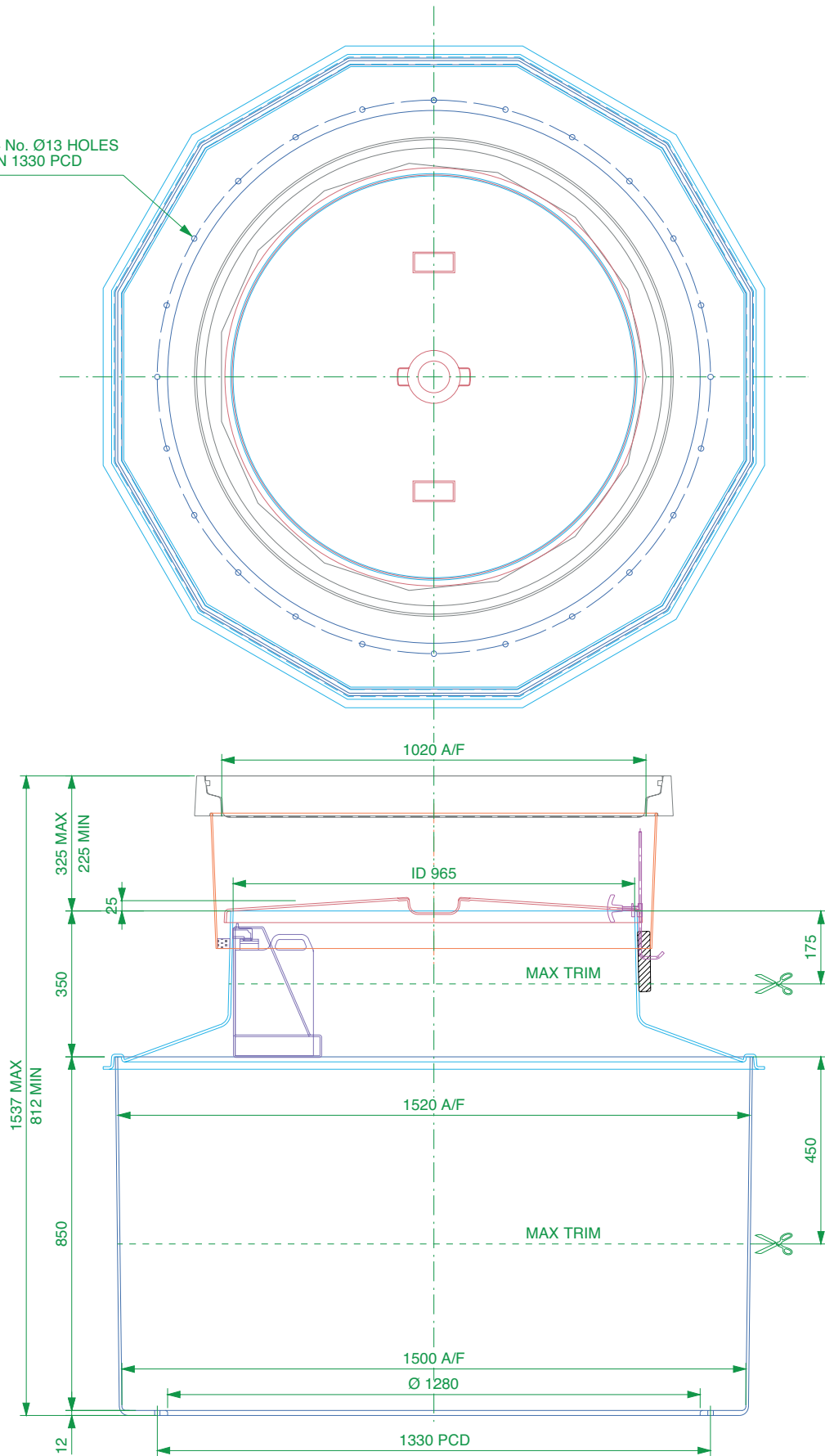

1.5m diameter 12 sided sump with reverse flange, corbel, adjustable height skirt, internal lid, and round 1020mm flat sealed cover and frame.

S16-3100

© Copyright

Issue: 04/06/2015

Page: 3 of 4



! VERY IMPORTANT !
 OUTER EDGE "A" OF FRAME SET 5 - 10MM
 ABOVE GENERAL FORECOURT AREA WITH
 CONCRETE RAMPED AWAY OVER 300MM.

TYPICAL INSTALLATION

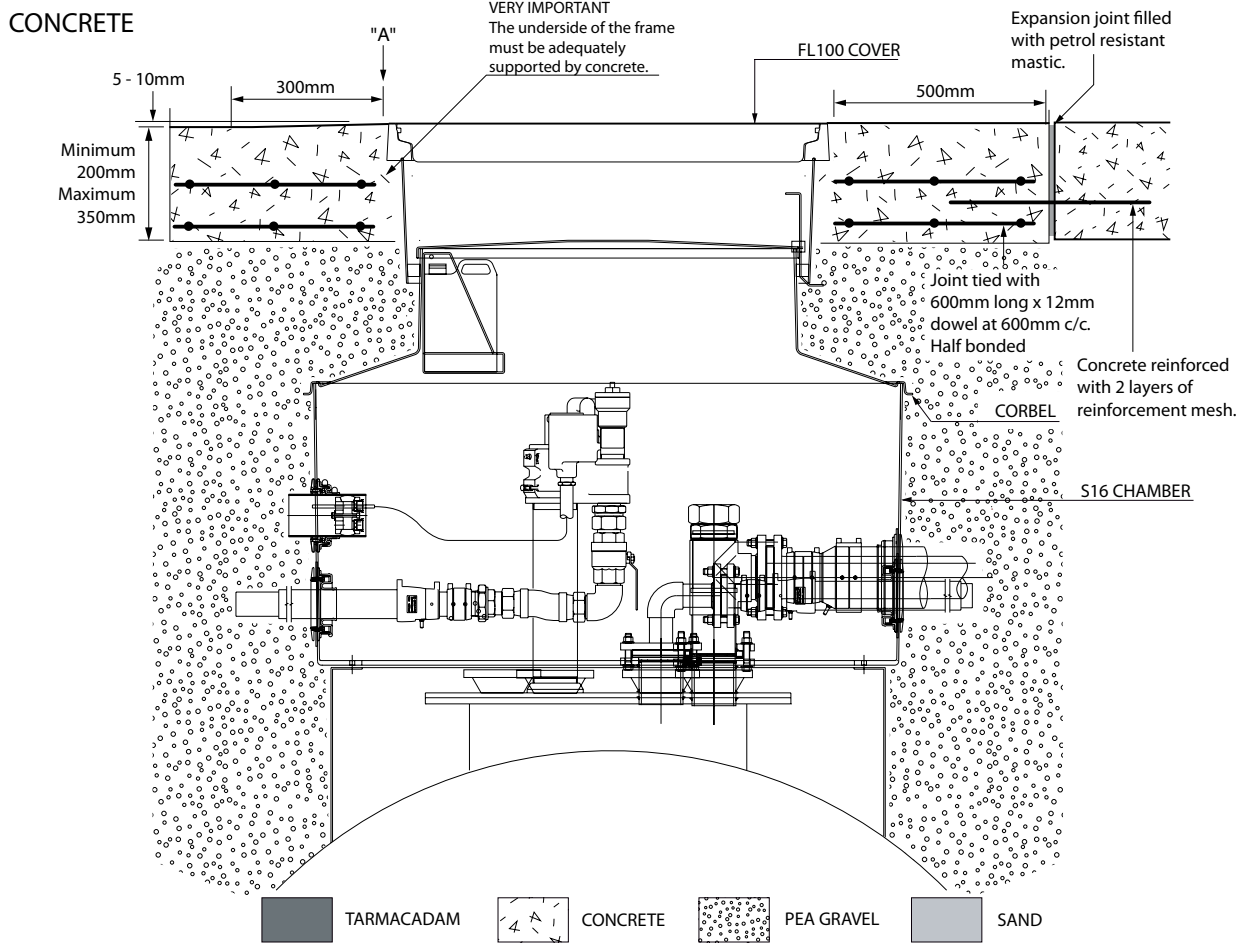

ALTERNATIVE INSTALLATION ADVICE

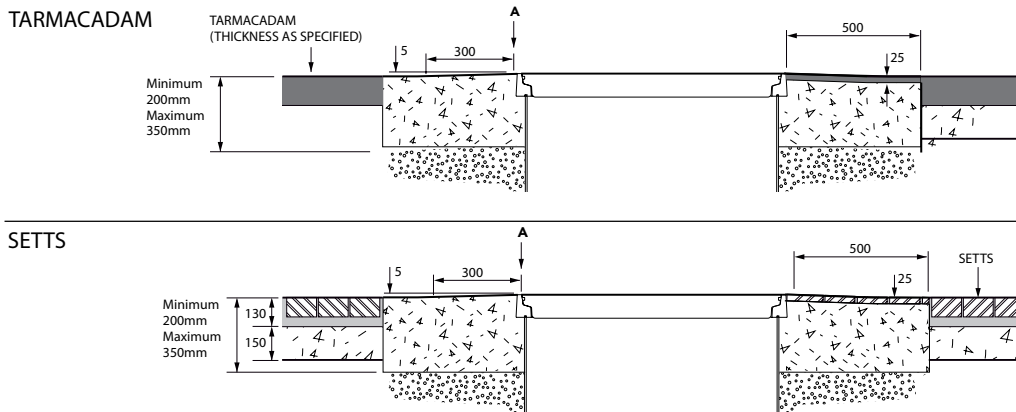

1.5m diameter 12 sided sump with reverse flange, corbel, adjustable height skirt, internal lid, and round 1020mm flat sealed cover and frame.

