

1.5m diameter 12 sided sump with solid base and manway lid adaptor, corbel, adjustable height skirt, internal lid, and round 1020mm flat sealed cover and frame

S16SQ-3100

© Copyright

Issue: 22/05/2015

Page: 1 of 4



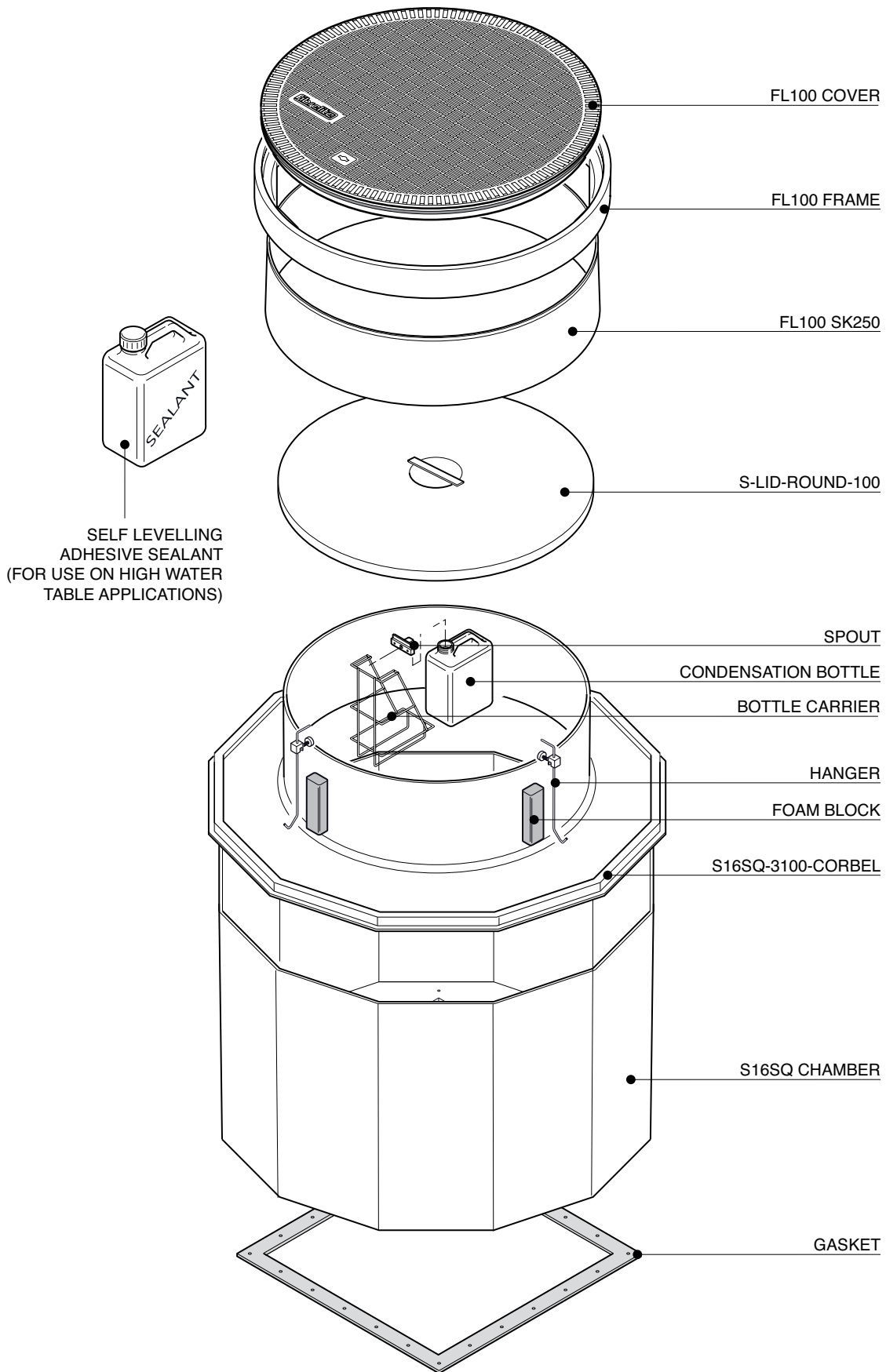

1.5m diameter 12 sided sump with solid base and manway lid adaptor, corbel, adjustable height skirt, internal lid, and round 1020mm flat sealed cover and frame

S16SQ-3100

© Copyright

Issue: 22/05/2015

Page: 2 of 4



FIBRELITE

PART OF  
**OPW**  
A **DOVER** COMPANY

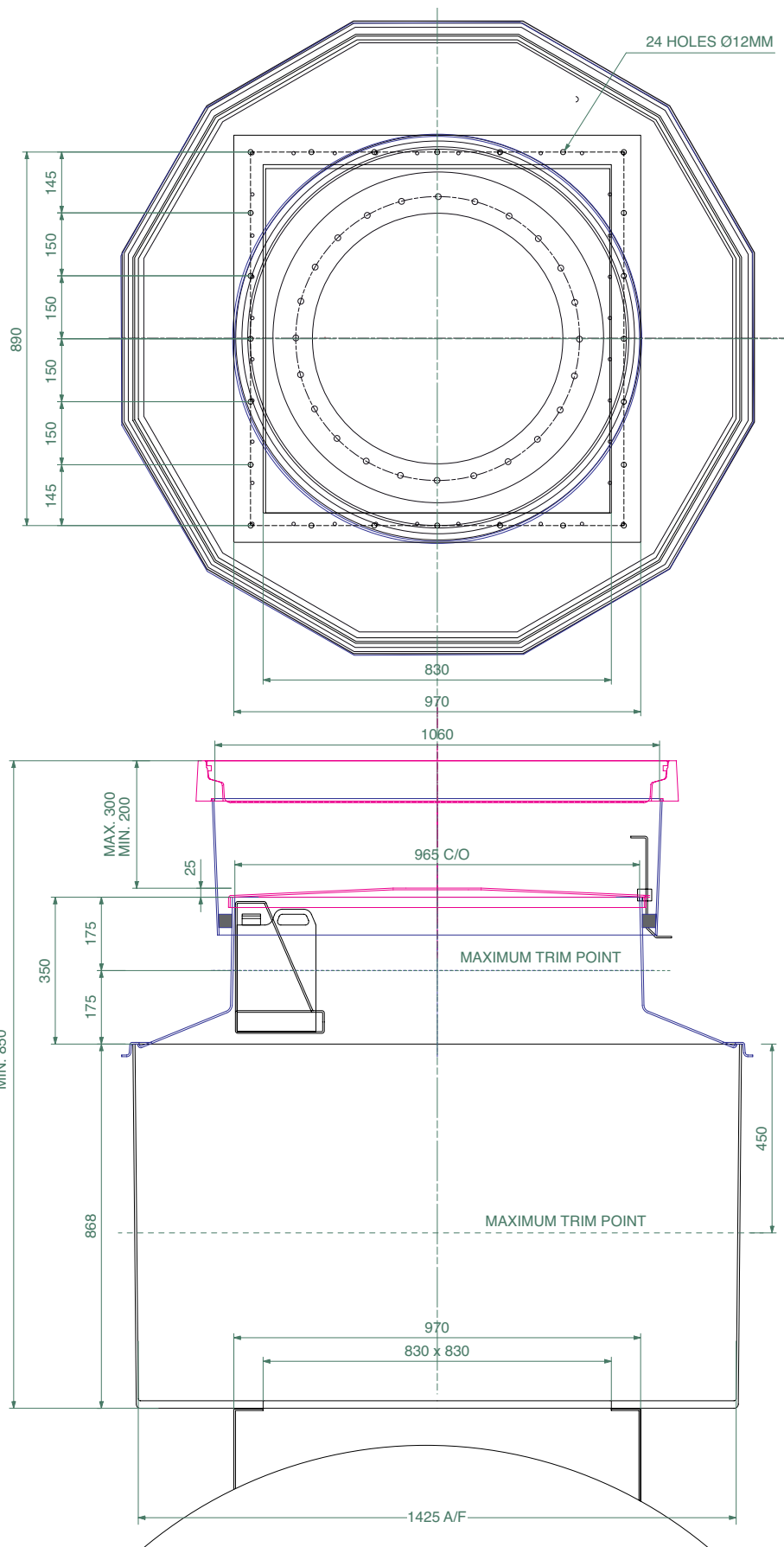

1.5m diameter 12 sided sump with solid base and manway lid adaptor, corbel, adjustable height skirt, internal lid, and round 1020mm flat sealed cover and frame

S16SQ-3100

© Copyright

Issue: 22/05/2015

Page: 3 of 4



PART OF  
**OPW**  
A **DOVER** COMPANY

**VERY IMPORTANT**  
 OUTER EDGE "A" OF FRAME SET 5 - 10MM  
 ABOVE GENERAL FORECOURT AREA WITH  
 CONCRETE RAMPED AWAY OVER 300MM.

**TYPICAL INSTALLATION**

**CONCRETE**

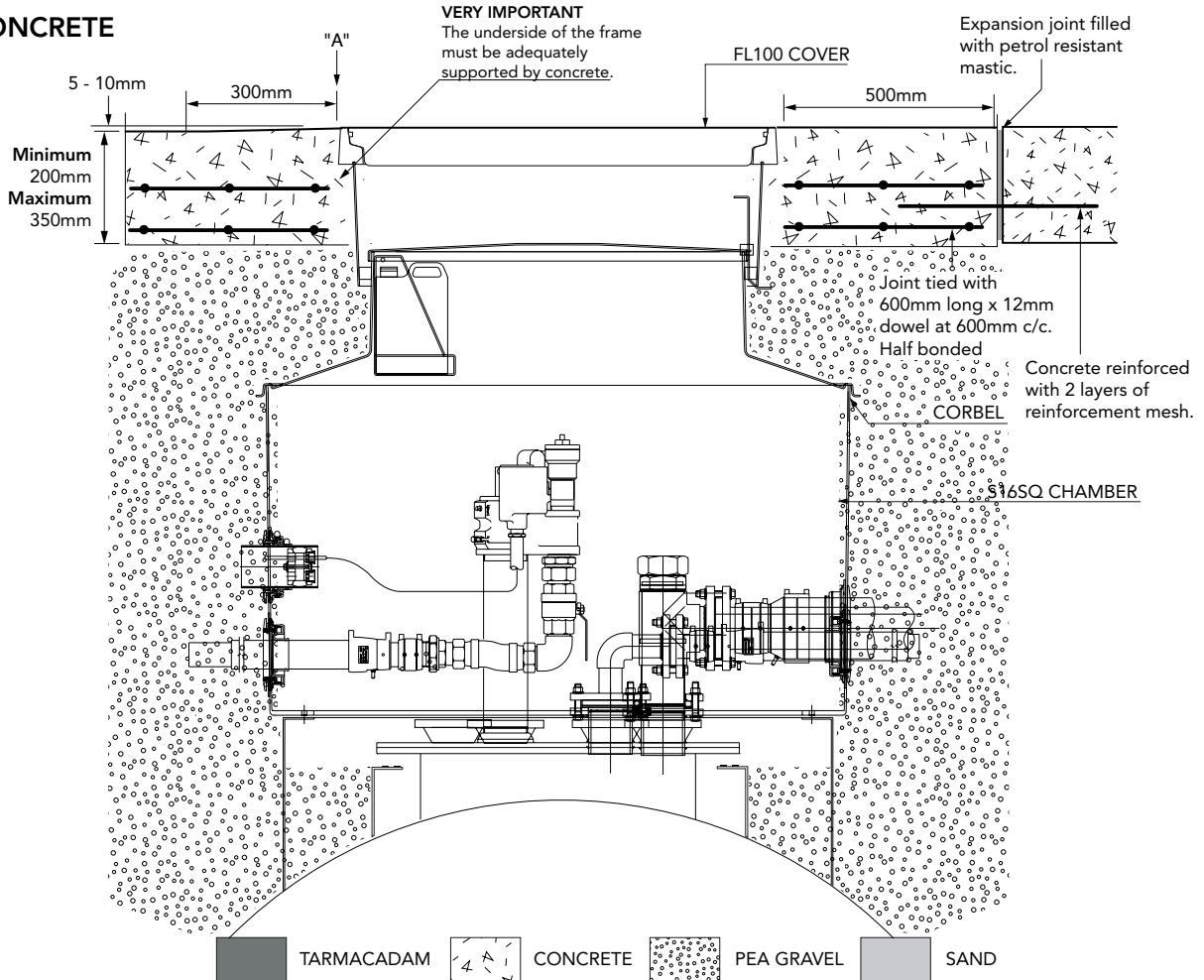

**ALTERNATIVE INSTALLATION ADVICE**

**TARMACADAM**

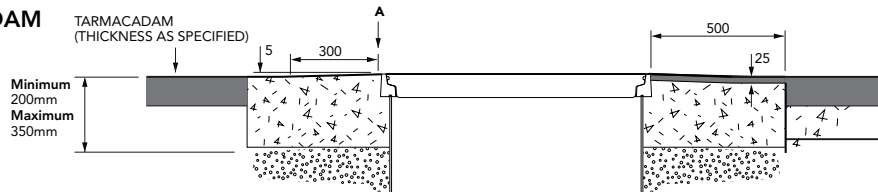

**SETTS**

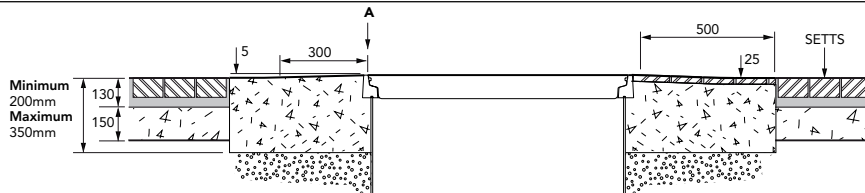

1.5m diameter 12 sided sump with solid base and manway lid adaptor, corbel, adjustable height skirt, internal lid, and round 1020mm flat sealed cover and frame

